

TOHO ELECTRONICS INC.

Program Controller TTM-339

Operation Manual

Thank you for purchasing Toho Electronics' TTM-339 series.
Before using the products, thoroughly read this manual for a better understanding of them.
Ensure to store this manual and use it whenever needed.

Contents

1 . Precautions on the use of the products ·	P 2
2 . Parts indication and Installation · ·	P 4
3 . Terminal connection diagram · · · · ·	P 7
4 . Terms and various functions · · · · ·	P 8
5 . Flow of mode change operation and run operation	P 1 8
6 . Measurement range and indicator resolution	P 2 8
7 . List of models · · · · ·	P 2 9
8 . Standard specifications · · · · ·	P 2 9
9 . Maintenance and Inspections · · · · ·	P 3 1

1. Precautions on the use of the products

Ensure to read this manual before using the equipment. Take care to understand the following for the safe use of the equipment. Ensure this manual to be in hands of a person using the equipment.

Precautions on safety









Alarms are defined and categorized into either one of four groups in this manual, depending on degrees of importance or risk in terms of the safe use of the equipment or prevention of accident or damage on the equipment. For each alarm, symbol is assigned as shown below.

Alarm symbols







 Danger	Improper handling of the equipment may cause fatality or serious injury for an impending reality.	 Caution	Improper handling of the equipment may cause injury or physical damage on it.
 Warning	Improper handling of the equipment may cause fatality or serious injury.	 Reminder	Care should be taken for ensuring safety.

An alarm categorized in the group of Caution may still yield to serious result, depending on circumstances.







Any symbol for the four groups intends to raise user's attention for important description. Carefully observe it.







	General caution, warning or prohibition without particularity.		Instruction on ground connection for the equipment with safety grounding terminals.		Hazard of pinched fingers on a particular portion of the equipment.
	Possible injury caused by touching a particular portion of the equipment under specific conditions.		Unspecific behaviors of general users.		Hazard of injury such as an electric shock due to disassembling or modification of the equipment
	Hazard of an electric shock under specific conditions		Hazard of injury due to high temperature under specific conditions		Hazard of burst under particular conditions.

Warning

	Improper wiring to the equipment may cause a failure, such as fire. Upon completion of wiring, ensure to verify the proper wiring before turning on electricity.
	Do not turn on electricity until all wiring is complete. Do not touch portions of high voltages such as power supply terminals, as an electric shock may be resultant.
	Install appropriate protective circuits externally if a failure or abnormality of the equipment may seriously affect related systems.
	Do not use the equipment out of the specified range, as it may fail or catch fire.
	Do not under any circumstance to modify or disassemble the equipment, as a failure may be caused, resulting fire or an electric shock.
	Do not use the equipment in ambience of flammable or explosive gases.

Caution

	Do not use the vacant terminals for wiring.
	Do not use a pointed object to operate keys.
	Do not turn on the power supply until wiring is fully complete in order to prevent an electric shock, failure or malfunctioning. For replacing a component connected on the equipment, ensure to turn off the power supply. For turning back on the power supply, do so after all wiring is complete.
	Ensure not to trap heat in the space surrounding the equipment in order to provide sufficient heat release.
	Do not put a metal piece or similar inside the equipment. A fire, an electric shock or failure may be caused.
	The equipment is designed for instrumentation. For its use in environments of high voltages or intense noises, take appropriate measures on the side of user's equipment.
	The equipment is designed for controlling physical values, such as temperatures, on general industrial facilities. Do not use it for subjects of control that may seriously affect human life.

	Turn off the power supply before cleaning the equipment, and wipe it with a soft dry cloth. Do not use thinners, as they may cause deformation or discoloration of the equipment.
	The equipment may cause radio disturbances in domestic settings. User is required to take appropriate measure.
	Ensure to tighten terminal screws at specified torque. Insufficient tightening the screws may cause an electric shock or fire.
	Ensure to observe precautions listed in this manual for the use of the equipment.
	Reprinting or duplicating this manual is prohibited.
	This manual may be revised without prior notice.

Precaution regarding Export Trade Control Ordinance

Investigation on client or application by an appropriate party is required so that the equipment is not used for mass destruction weapons and such (military application, military facilities, etc.).

Notation convention in this manual

Summary notation

Abbreviations in alphabetical characters are used for the diagrams and text in this manual. Some major examples are as follows.

Abbreviation	Term
PV	Present value
SV	Setting value
AT	Auto-tuning
MV1	Primary operating amount
MV2	Secondary operating amount
CT	Current transformer

0	1	2	3	4	5	6
0	1	2	3	4	5	6
7	8	9	Minus	Period	Slash	
7	8	9	-	.	/	

A	B	C	D	E	F	G
A	B	C	D	E	F	G
H	I	J	K	L	M	N
H	I	J	K	L	M	N
O	P	Q	R	S	T	U
O	P	Q	R	S	T	U
V	W	X	Y	Z		
V	W	X	Y	Z		

2. Parts indication and Installation

2.1 Full panel face

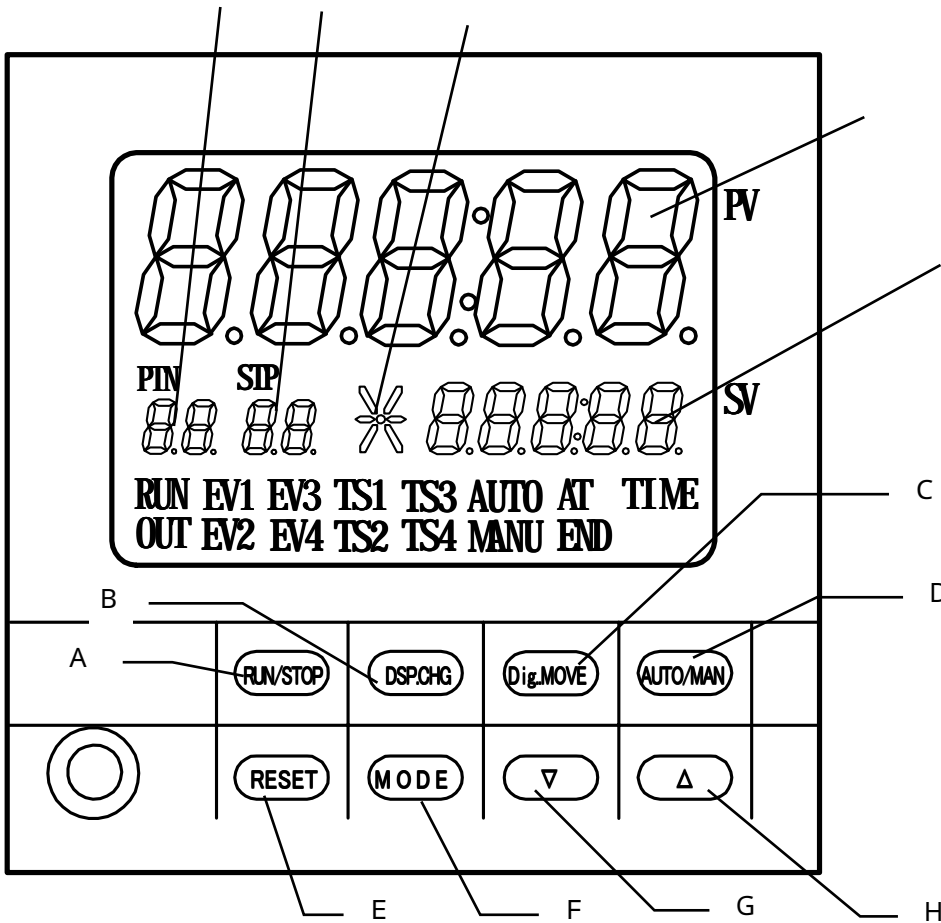

2.2 Segment display section

No.	Segment character	Content
	PV (5 digits in the upper row)	Displays PV, etc.
	SV (5 digits in the lower row)	Displays SV, etc. Fixed to 0 during a stop. Displays "TIME" during a timer run.
	Pattern digit (2 digits in the lower row left)	Displays the pattern No., etc. presently in selection.
	Step digit (2 digits in the lower row right)	In a stop: Displays the number of steps of the pattern presently in selection. In a run: Displays the step No., etc. presently in progress.
	Operating status (lower row center; 6 segments)	Indicates the program operating status.

2.3 Key

No.	Name	Content
A	RUN/STOP key	Used for run start/stop, temporary stop, etc.
B	DSP.CHG key	Used for display switchover, etc.
C	Dig.MOVE key	Shifts the set digit leftward during setting.
D	AUTO/MAN key	Switches over MANU/AUTO.
E	RESET key	Used for screen return, etc.
F	MODE key	Used for changing a setting item, etc.
G	▽ key	Used for decreasing a numerical value, etc.
H	△ key	Used for increasing a numerical value, etc.

2.4 Lamp display section

Lamp character	Content
PTN	Lights up while a pattern in display.
STP	Lights up while a step in display.
RUN	Lights up during a program run.
OUT	Lights up at the heating output ON.
EV1	Lights up at occurrence of Event 1.
EV2	Lights up at occurrence of Event 2.
EV3	Lights up at occurrence of Event 3.
EV4	Lights up at occurrence of Event 4.
TS1	Lights up at Time Signal 1 ON.
TS2	Lights up at Time Signal 2 ON.
TS3	Lights up at Time Signal 3 ON.
TS4	Lights up at Time Signal 4 ON.
AUTO	Lights up during an automatic run.
MANU	Lights up during a manual run.
AT	Lights up during an auto-tuning.
END	Lights up at the output ON while End Signal in use.
TIME	Lights up at the time being set.

2.5 Lamp display section

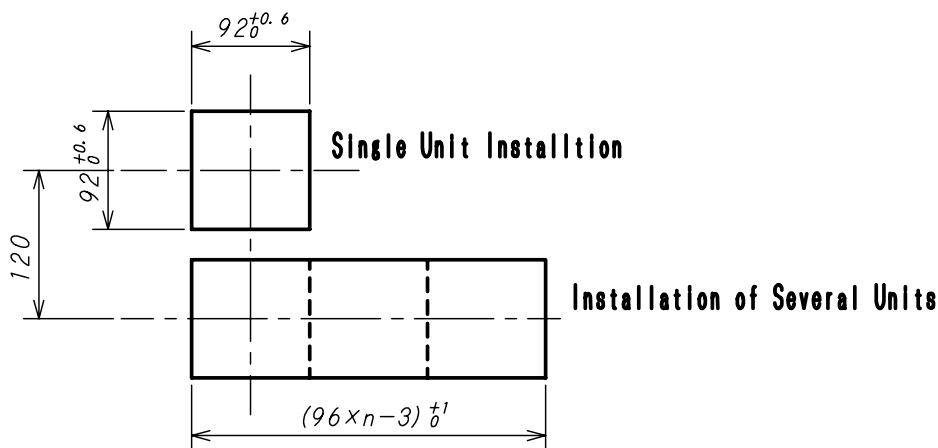

2.6 Outer Dimensions

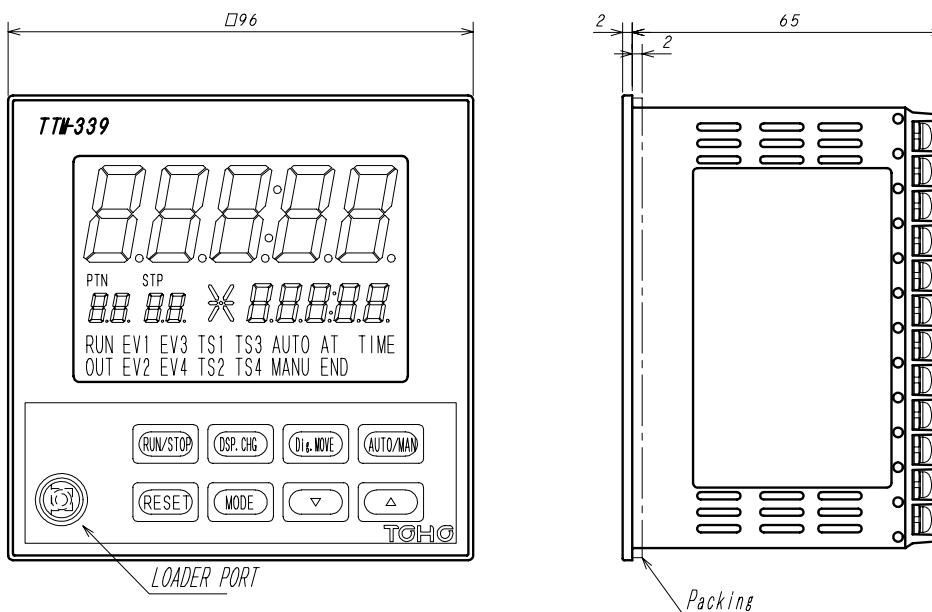

2.7 Precautions on installation

Warning

Ensure to turn the power supply off before beginning removal or reinstallation of the equipment in order to prevent an electric shock or equipment failure.

Ambient temperature and humidity (the equipment to be used in the specified range as listed below)

- (1) Temperature range: 0 - 50 °C
- (2) Humidity range: 20 - 90% PH (no dew condensation allowed)
- (3) Installation gradient: Base plane \pm 10 degrees

Do not install the equipment in the following places.

- (1) Where temperature abruptly changes to generate dew
- (2) Where corrosive or flammable gases are generated
- (3) Where water, oil, steam or chemicals splatter
- (4) Where vibration or noise is directly applied
- (5) Where dusty or salty ambience, or many iron scraps is present
- (6) Where direct sunlight is received
- (7) Where circuits may negatively be affected by static electricity, noise or magnetism
- (8) Where direct warm or cool air is received from an air-conditioner

Precautions on installation

- (1) Provide sufficient space for ventilation so that the ambient temperature does not rise to 50 °C or higher. In case that the temperature of 50 °C or higher is suspected, use a fan or air-conditioner to cool the ambience. Take care that no cold air flows directly on the equipment.
- (2) Do not install the equipment on a device that may generate large heat, such as heater and transformer.
- (3) Install the equipment away as much distant as possible from high-voltage devices, power lines or power equipment.
- (4) Do not block off the ventilation opening on the equipment. Ensure a sufficient gap between stacked units of equipment.

2.8 How to install or remove the equipment

Installation on a panel

- (1) Make an opening on the panel.
- (2) Insert the equipment into the opening.
- (3) Install the mounting attachment from behind the panel.
(Ensure that the equipment is securely fixed)
 - * Conduct wiring after the equipment is installed.
 - * Turn on the power after the wiring.

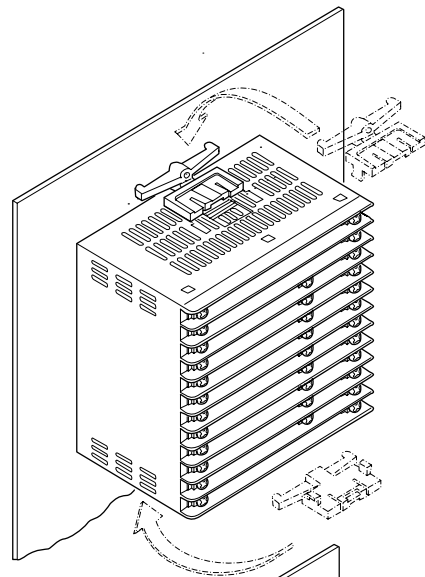

Removal from the panel

- (1) Turn off the power.
- (2) Disconnect the wiring.
- (3) Insert a flat-head screw driver into the clearance formed between gabs on the equipment and attachment. Turn the screw driver clockwise or counterclockwise to dislocate the gabs to remove the attachment from the equipment.
- (4) Remove the equipment from the panel.
 - * Ensure to conduct removal work after turning off the power.

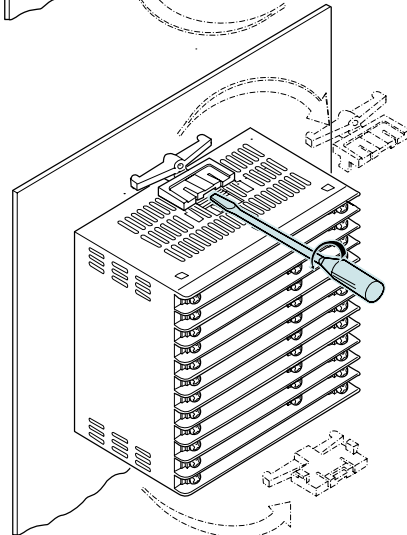

3. Terminal connection diagram

Power supply 100 to 240 VAC		X	A	Communications RS-485		+	EV4	Open collector output
Not in use		②⑤	B			+	TS1	
OUT1 (Relay/SSR/4 -20 mADC)	- C	②⑥	Pattern 1	No-voltage contact input		+	TS2	
	+ NO	②⑦	Pattern 2			+	TS3	
OUT2(None/Relay/ SSR/ 4 -20 mADC)	- C	②⑧	Pattern 3			+	TS4	
	+ NO	②⑨	Pattern 4			+	TIME	
Not in use		③⑩	RUN/RDY			-	COM	
		③⑪	Operation switchover					
Relay contact output	EV1	③⑫	Step feed	Relay contact output	②⑪	CT input		
	EV2	③⑬	COM		②⑫	Sensor input * See below.		
	EV3	③⑭	END signal		②⑬			
	COM	Y	COM		②⑭			

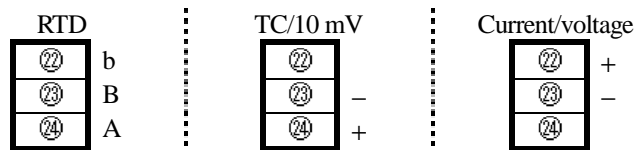

Precautions on wiring

 Warning	Do not turn on the power until all wiring is complete in order to prevent an electric shock or equipment failure.
--	---

For inputs from a thermocouple, use the specified wires or compensating leads.

For inputs from a resistance temperature detector, use wires that the wire resistance of leads is small and no resistance difference is present among 3 wires (3-wire type).

Provide input signal lines distant from power supply lines, power lines or load lines so as not to affect input signal lines with noise induction.

Wire the power supply for instruments such that they do not receive noises from the power supply for power devices.

The use of a noise filter is recommended in case that the equipment is vulnerable to noises.

Take care the following when a noise filter is used.

Install the noise filter as close to a temperature controller as possible.

Wire the instruments in as short a distance as possible to output lines (secondary side) of the noise filter and power terminals for the temperature controller.

Isolate the noise filter input line (primary side) from its output line (secondary side).

High-frequency elements of noises may be induced, resulting in no provision of much noise attenuation effect as expected, in case of input and output wires being close one another, such as being bundled together or installed in a same duct or tube.

Wire the grounding wire of the noise filter in as short a distance as possible.

A long grounding wire is equivalent to insert of an inductance, resulting in deteriorated high-frequency characteristics.

Before installing the noise filter, peel off the paint applied on a mounting plate of the noise filter as appropriate, in order to reduce the contact resistance between the noise filter and equipment housing.

For the power supply, use and twist wires that cause less voltage drop.

For the equipment being activated, it takes about 4 seconds after its power turns on. Use delay relays when using the equipment for generating signals for interlocking circuits.

The equipment is not attached with power supply switch fuses. Separately install fuses in proximity of the equipment, as needed.

Recommended fuse rating: Rated voltage of 250 V and rated current of 1 A

Use crimping terminals that match screw sizes.

Size of crimping terminal: Terminal width of 6 mm or smaller

Crimping terminal recommended

Manufacturer: NICHIFU

Model: ICTV-1.25Y-3N (Y terminal)

ICTV-1.25-3S (round terminal)

Tightening torque recommended: 0.5 N·m (5 kgf·m)

Applicable wire

Use wires in sizes suitable for the terminals.

The use of shielded wires is recommended.

For Pt100 (resistance temperature detector), use identical wires of low lead resistance and no resistance difference among 3 wires.

4. Terms and Various Functions

4.1 Program run

* The following number of steps is fixedly set, depending on the number of patterns.

Pattern No.	1	2	3	4	5	6	7	8
Step No.	99	49	33	24	19	16	14	12

Pattern No.	9	10	11	12	13	14	15
Step No.	11	9	9	8	7	7	6

To make control, SV is changed parallel to the temperature and time set for each pattern.

If a setting is made to the lower limit within [a setting range - 1] (“----” to be displayed) in the temperature setting for each step, steps following the said step is ineffective and no setting parameter is displayed.

The pattern run ends at one step prior to the step set as “----.”

Neither the step temperature nor the step time in a run can be changed.

If the setting temperature of the step 1 is set at SLL for a PV start, the time of step 1 is effective and a timer run begins. (The normal PV start begins with the step 2.)

“TIME” is displayed in the SV display frame.

If the setting temperature for all steps is 0, setting a temperature for a step results in the next step automatically being set to the same temperature (only at key operation).

If the step time is set above the upper limit within the setting range (“~~~~” to be displayed), the step continuously runs at the setting temperature.

Each pattern repeats for the number of times that has been executed. When the setting is set to “0”, it will continue to repeat until it is stopped with key operation. (max. 9999 times)

During a run, the TIME output is ON.

For display during the program run, see Section 5.3.2 “Auto run (normal mode).”

The following is displayed upon termination of the program.

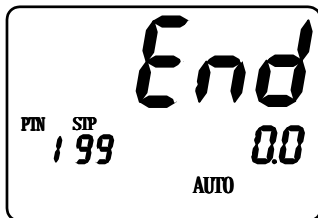

- The screen shown in the left is the normal one.

4.2 Step feed/step return

Holding the “△” key pressed for 3 seconds during a run results in the step feed to transfer to the next step.

Holding the “▽” key pressed for 3 seconds results in the step return to transfer to the step one previous to the current step.

In the case of the external drive signal selection being ON, the step feed is executed when open of the step feed DI changes to closed.

Only the timer is reset when the step return is executed at step 1 (or the leading step).

If the step feed is executed at the step for the endless setting, END is established.

4.3 Elapsed time increase/decrease

During a program run, pressing the △/▽ key on the elapsed time screen results in an increase/decrease of the elapsed time.

The unit of the elapsed time is minute. Counting the number of seconds continues.

The change range of the elapsed time is 0 to [the setting time in a run - 1].

The change range of the elapsed time for a wait zone is 0 to [the setting time in a run + the wait time - 1].

Execution of an increase/decrease in the wait zone results in an increase/decrease of the elapsed time; however, setting the elapsed time below the setting time results in a return to the normal step run but not to the wait zone.

This function is ineffective for an end signal.

4.4 Wait function

For the current step transferring to the next step, the next step does not begin if PV has not reached the wait zone (similarly, if PV has overreached) after the step time elapsed.

However, if the wait time elapses, the next step begins at that point.

The above operation is executed by selecting 0 to 4 for each step, or by setting value for 1 to 4.

Selecting 0 indicates no function.

In the case of [the wait zone setting = 0], in-a- wait is effective until PV goes beyond SV.

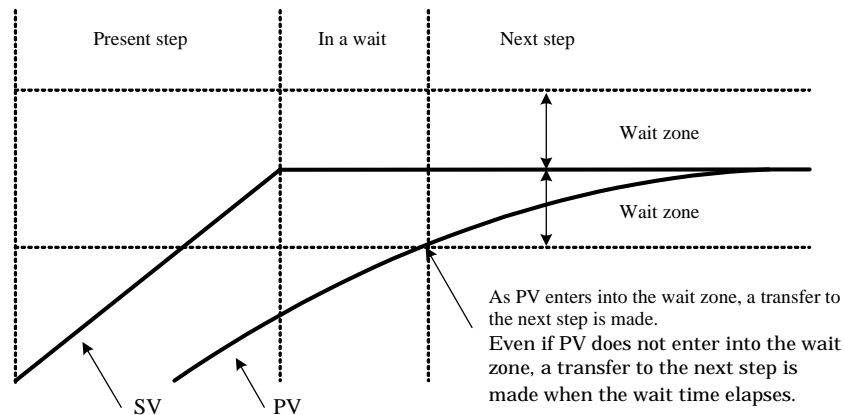

4.5 Three-zone PID function

Numerical values of P, I, D and PC are switched over at each of the low, intermediate and high temperatures.

The ranges of the three zones are as follows:

- Low temperature (PID No. 1): SLL to intermediate point 1
- Intermediate temperature (PID No. 2): Intermediate point 1 to intermediate point 2
- High temperature (PID No. 3): Intermediate point 2 to SLH

4.6 Auto tuning function

Auto tuning starts at each of low, intermediate and high temperatures.

Auto tuning starts when the temperature at which the auto tuning is to be performed is set on each startup screen and the RUN/STOP key is pressed or by an Auto tuning start command of the communication.

During the auto tuning, AT-1 (to 3) and SV are alternately displayed in the SV display digit, and ATALL and PV are alternately displayed in the PV display digit.

Re-pressing the RUN/STOP key results in a stop of the auto tuning.

If the auto tuning has not terminated 3 hours after its start, an AT error is established and the run stops, displaying "ERR2."

Attempting an auto tuning during an automatic run results in first a temporary stop and then start of the auto tuning. During a manual run, the auto tuning is not possible.

4.7 PV start/SV start

At a start of the program run after selecting the PV start and SV start, the start SV indicates the following:

PV start:

The run starts from the ramp step of upward slope in which the measurement temperature is included.

In addition, the run starts from the elapsed time, of which amount is assumed to elapse to come to the start point.

The calculation is made with the start point of 0°C /0 digit.

For below 0°C /0 digit, the calculation is made with the elapsed time of 0 minute.

SV start: The program run starts from the SV start temperature setting.

4.8 Time signal output

At starting each step, the time signals 1 to 4 are turned on upon elapse of the time set on the ON delay timer. Then, the output is turned off upon elapse of the time set on the OFF delay timer. During the time signal output ON, corresponding lamps of TS1 to TS4 light up. Select the function selection among 0 to 5 of TS 1 to 4 at each step; if either one of 1 to 4 is selected, the above operation is performed with the setting; if 0 is selected, no function is available; if 5 is selected, ON is always set during the selection step. If the time is set backward by using the Δ or ∇ key, even after elapse of time, the output returns to the one corresponding to the point at which the time set backward and time counting starts at that point, i.e., in the middle of the way. Example: If the elapsed time is returned by 5 minutes by using the ∇ key 3 minutes after the OFF delay terminates, the output turns on and the OFF delay counts for 2 minutes.

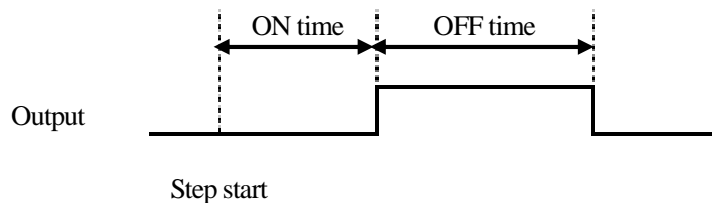

4.9 In-a-run signal output/end signal output selection function

The use purpose of one relay output is selected from either in-a-run signal output or end signal output.

4.9.1 When selecting the in-a-run signal output

During a run, the relay output is always ON as in-a-run signal output.

4.9.2 When selecting the end signal output

At termination of the program run, the output as the end signal output is turned on or off according to the following flow.

If the setting is above the maximum value within the setting range (“~~~~~” to be displayed), the output remains turned on until the reset status described in Section 5.3.1 is established.

Also, the END lamp lights up.

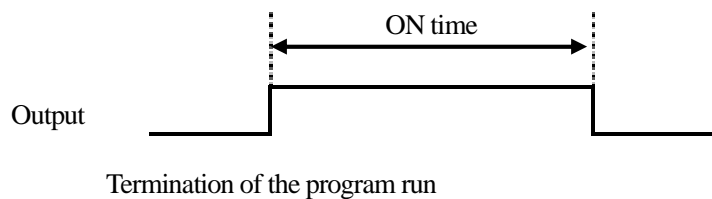

4.10 DI (external input)

Operation including run can be performed via DI through the external drive signal selection.

For the function of each DI, see Sections 4.10.1 to 4.10.4.

No operation is performed for [external drive signal = OFF].

4.10.1 Run/reset DI

The following operation is performed when ON continues for 2 seconds after the external contact open (OFF) changes to the external contact closed (ON):

During a run: The run stops.

During a stop: A run starts.

4.10.2 Hold DI

The following operation is performed when ON continues for 2 seconds after the external contact open (OFF) changes to the external contact closed (ON):

During a run: The run stops momentarily.

During a momentary stop: The run restarts.

4.10.3 Step feed DI

The step changes when the external contact open (OFF) changes to the external contact closed (ON) during a program run.

4.10.4 Patterns 1 to 4 DI

A pattern is selected from 1 to 15, which are configured by combination of the external contacts 1 to 4 closed (ON) and open (OFF).

No switchover of a pattern No. is possible during a run.

If all external contacts 1 to 4 are open (OFF), choose the pattern No. selected in the pattern No. setting mode.

Pattern 1 DI: 1

Pattern 2 DI: 2

Pattern 3 DI: 4

Pattern 4 DI: 8

Example: If both pattern 1DI and pattern 3DI are ON, selected pattern No. is: $1 + 4 = 5$.

4.11 Auto run (AUTO)/manual run (MANU)

The base of a run is the auto run (AUTO); the auto run, however, changes to the manual run (MANU) by holding the AUTO/MANU key pressed for 3 seconds.

No control is performed during a manual run, but the operation amount is output in a display.

The displayed operation amount is identical to the SV displayed in the lower row on the PV/SV screen in the normal mode.

Pressing the Δ/∇ key in this status results in a change of the operation amount to be output.

The operation amount and step time are as follows at the start of a manual run:

– Operation amount

In the case of in-a-stop: Starts with the operation amount of 0.0%.

In the case of in-a-run: Starts with the operation amount at the time of switchover

– Step time

In the case of in-a-stop: Remains in a stop (no step time counting begins).

In the case of in-a-run: The step time elapses (remains in a stop during a momentary stop).

Re-holding the AUTO/MANU key pressed for 3 seconds results in a return to the auto run.

The AUTO and MANU lamps lights up as follows:

During an auto run: The AUTO lamp turns on and the MANU lamp turns off.

During a manual run: The AUTO lamp turns off and the MANU lamp turns on.

The output interval during a manual run is fixed to 10 seconds.

4.12 Operation amount limiter

By using the operation amount function selection, “no limit function” can be set or two types of operation amount limiters can be effective.

In addition, two types of limiters can be effective by using the other operation amounts limiter setting described in Section 4.13.3.

4.12.1 Operation amount limiter

The operation amount is limited by using the primary/secondary control operation amount upper limiters and Primary/secondary control operation amount lower limiters selected by the operation amount limiter function selection at each step.

If the operation amount limiter function selection is 0, then 0.0 to 100.0 % is applicable.

4.12.2 Operation amount current limiter

The operation amount and current value are limited at each point obtained by dividing SLL to SLH into 10. At the operation amount limiter points 1 to 11, the operation amount resulted from calculation is limited.

At the current value limiter points 1 to 11, the operation amount is limited by the operation amount at the current value limiter point determined from a measured current value and present operation amount if the measured current value at each point exceeds the value [setting value - current limiter sensitivity].

This operation amount changes each time when measuring the current value.

The final operation amount is limited by using either smaller limit of the above two.

The function is effective when [OUT 2 selection = 4 to 20mA], CT existent, [CNT = 1] and operation amount current limiter effective. OUT2 outputs MV1 (equivalent to OUT1).

Operation amount

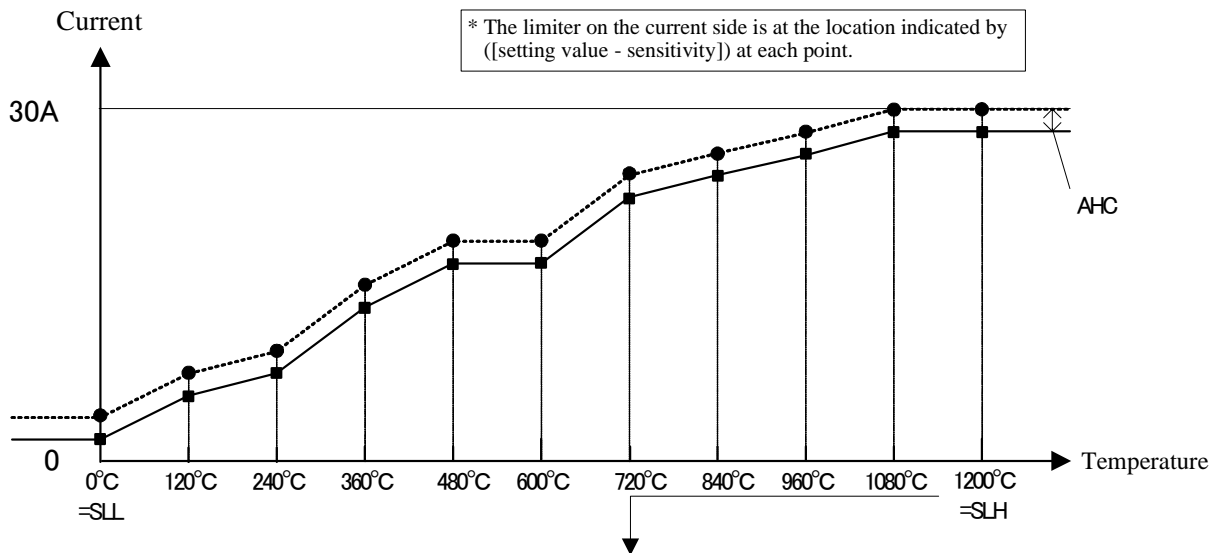
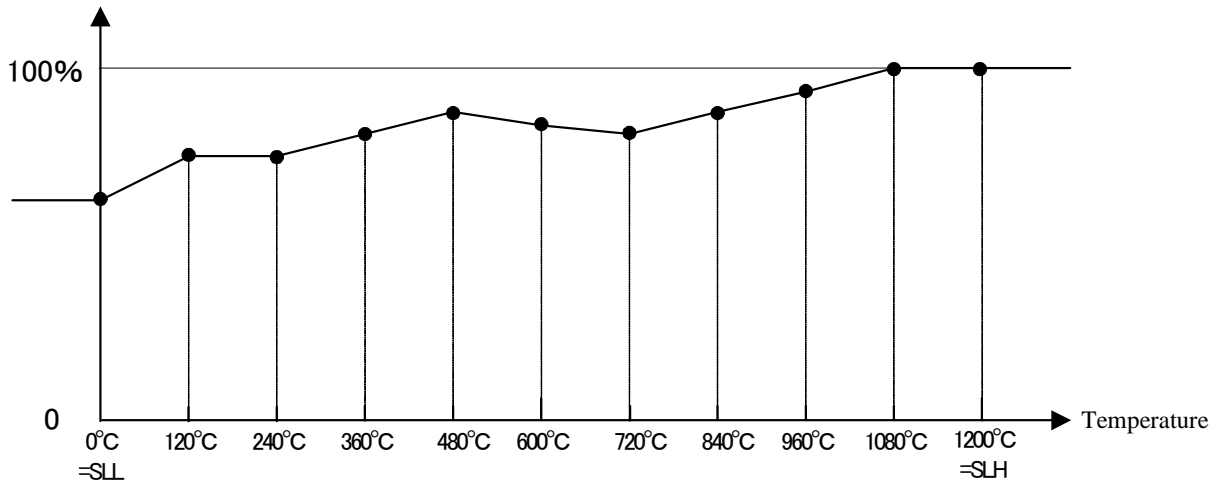

- For an input below the table range, the SLL operation amount and the current value are used for calculation.
- For an input above the table range, the SLH operation amount and the current value are used for calculation.

Example:

Assume the following for various settings and PV:

PV = 120 °C, operation amount limiter point 2 = 75.0%, current value limiter point 2 = 10.0 A, present operation amount = 60.0% and AHC = 1.0 A.

– If measured current valued = 15 A:

Based on the relation [0 to present operation amount (60.0%) = 0.0 to measured current value (15.0 A)], the operation amount [current value limiter point 2 (10.0 A) - current limiter sensitivity (1.0 A)] is to be determined. The calculation results in the operation amount of 36.0%.

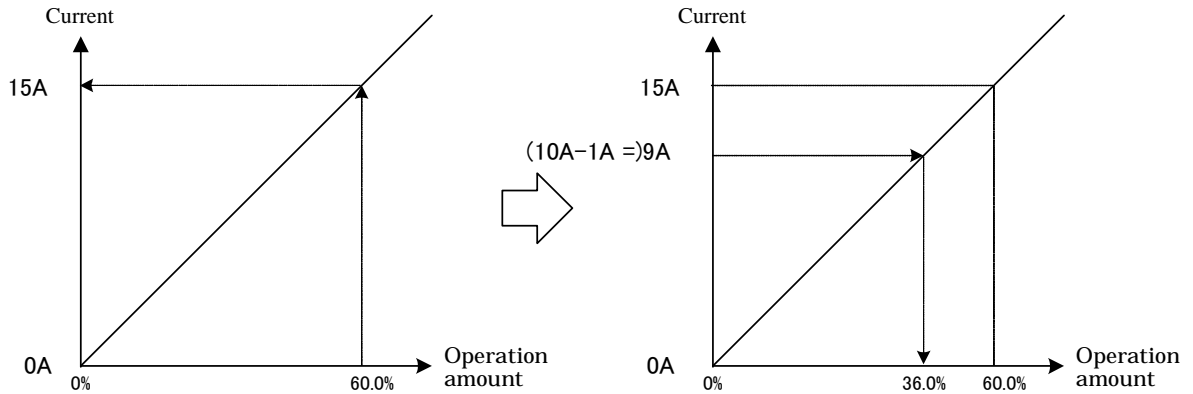

* The operation limiter point 2 = 75.0%; as this amount is larger than the operation amount resulted from the calculation, the operation amount is eventually limited at 36.0%.

4.13.3 Other operation amounts limiter setting

4.13.3-1 Primary/secondary control operation amount change limiter increase setting

Setting items:

Primary/secondary control operation amount change limiter increase setting: 0.0 to 549.9 [%] (no function by setting at 0.0 [%])

Operation description:

The increase rate of variation of a calculated operation amount is limited.

The operation amount allowed to increase for a second is set in percent.

The setting is effective during AT.

If the setting is changed, control results also changes; redo AT.

If the setting is 100%, the variation increases only up to 20 % for input sampling (200 ms).

To increase up to 100% for input sampling (200 ms), set at 500%.

$(1 \text{ second} \div 200 \text{ ms}) \times 100\% = 500\%$

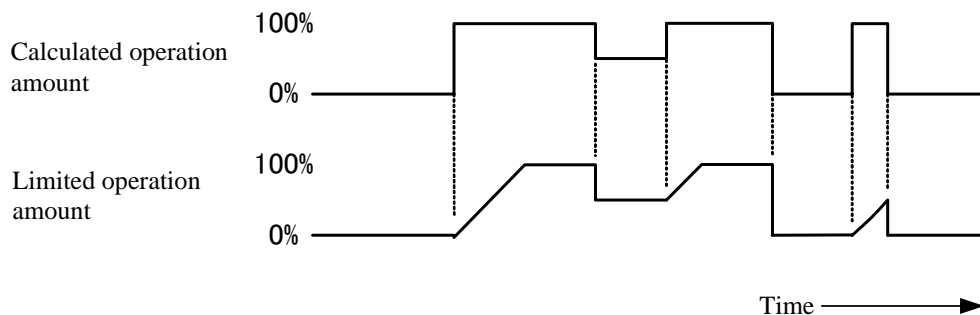

4.13.3-2 Primary/secondary control operation amount increase time

Setting items:

Primary/secondary control operation amount increase time: 0 to 3600 [second] (no function by setting at 0 [second])

Operation description:

For a remote run, apply a limit on the operation amount such that the ratio of the operation amount to the calculated operation amount is from 0% at the start to 100% at the setting time.

The setting is effective also during AT.

If the setting is changed, control results change; redo the AT.

Operation is performed only at the control start (RDY to RUN or MAN or AT)

Care must be used, as no limit applies by the operation amount increase time after the setting time.

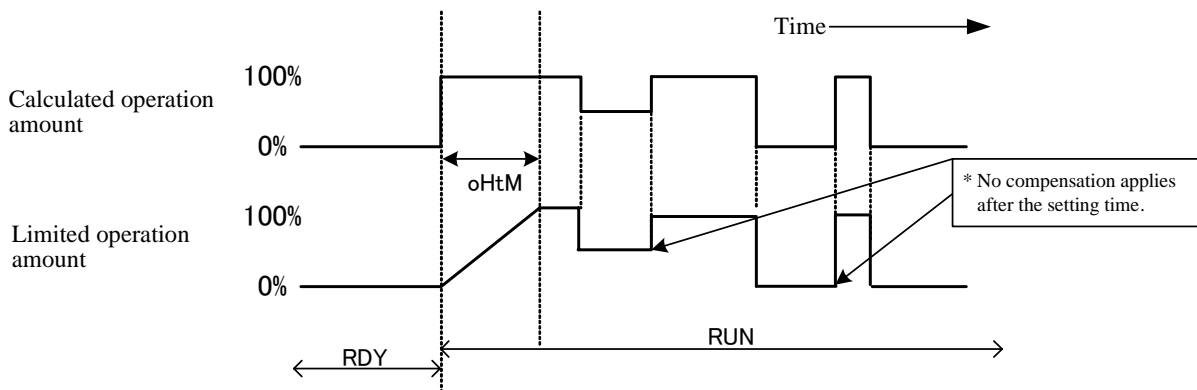
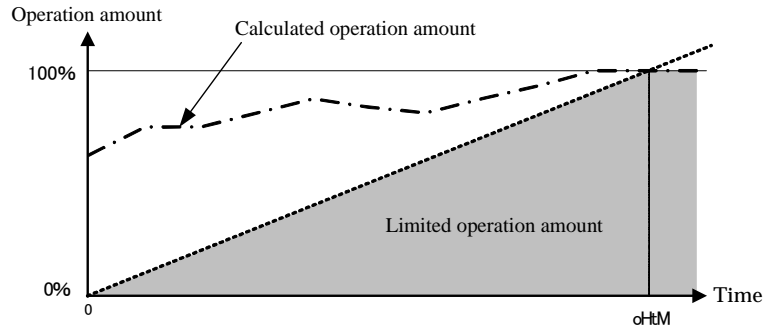

4.14 Key lock

When a change of each parameter is attempted in a lock after lock ON/OFF is elected, "LOC" is displayed in the SV display section.

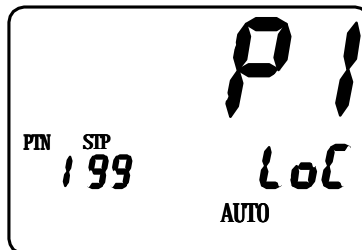

4.15 PV filter setting

4.15.1-1 PV filter setting

This setting is a function to achieve the CR filter effect on the software by performing a primary delay calculation on the PV of the input 1.

The filter effect is set with the damping time constant [t].

(Damping time constant is defined as time when PV reaches about 63% in a stepwise change of input.)

* CR filter: Filter of first order lag

Application of a PV filter:

- (1) By elimination of high-frequency noise, effect of noise is mitigated when electric noise applies to input.
- (2) Response can be delayed for an abrupt change of input.

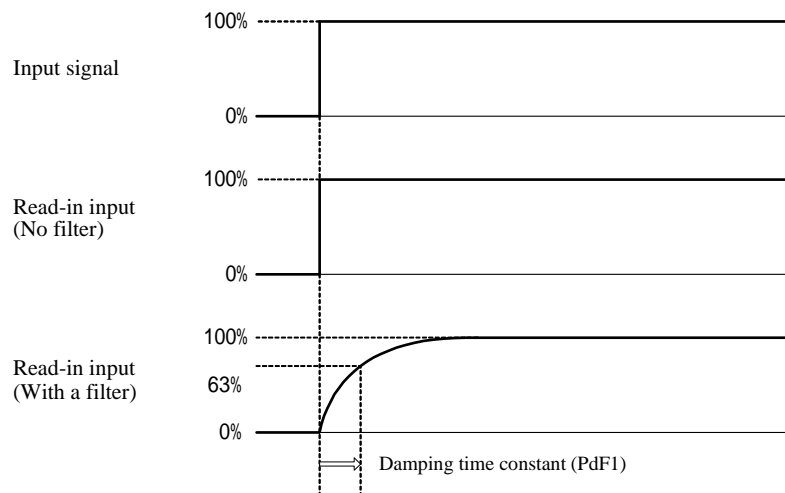

4.15.2 B thermocouple/PR40-20 special PV filter setting

This setting is a function for the input 1 to add the PV filter setting time further with a limitation of a particular range on the B thermocouple and PR40-20.

Filter effect is set by the damping time constant [t].

The effective range of the set filter is as follows:

- (1) B thermocouple: In the case of 400°C or below
- (2) PR40-20: In the case of below 800°C

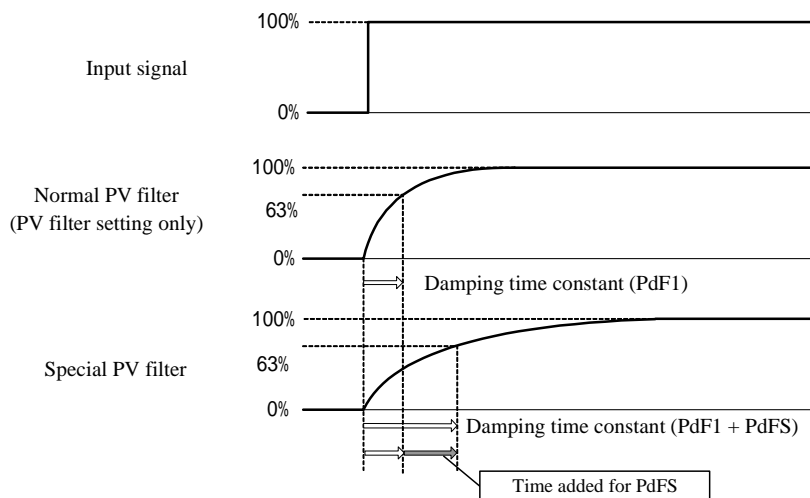

4.16 Event alarm

By setting the events 1 to 4 function setting, outputs of AL 1 to 4 are turned on if PV is located within the alarm range. Corresponding AL1 to AL4 lamps light up.

By switching over the events 1 to 4 polarities, selection of open/closed is possible at the turn-on.

Output is also turned on at occurrence of a loop abnormality when the events 1 to 4 function 2 setting is effective.

* For loop abnormality, see Section 8.17 “Loop abnormality.”

The setting can be released by using the key or reset DI, provided that the following condition is met:

- (1) Normal status at the release
- (2) Standby existent even if abnormality status at the release

Judgment process is performed only during a run (no judgment made during a stop).

Restoration from a power outage is made for the status previous to the outage.

4.17 Loop abnormality

When the primary/secondary control loop abnormality PV change amount setting is not 0, the PV change amount is determined every loop abnormality time setting time if the present step is a soak.

Consequently, “loop abnormality” occurs if the following condition is met: $PV \leq \text{Primary/secondary control loop abnormality PV change amount setting}$.

Function OFF is established if the primary/secondary control loop abnormality PV change amount setting is 0.

4.18 Blind Function

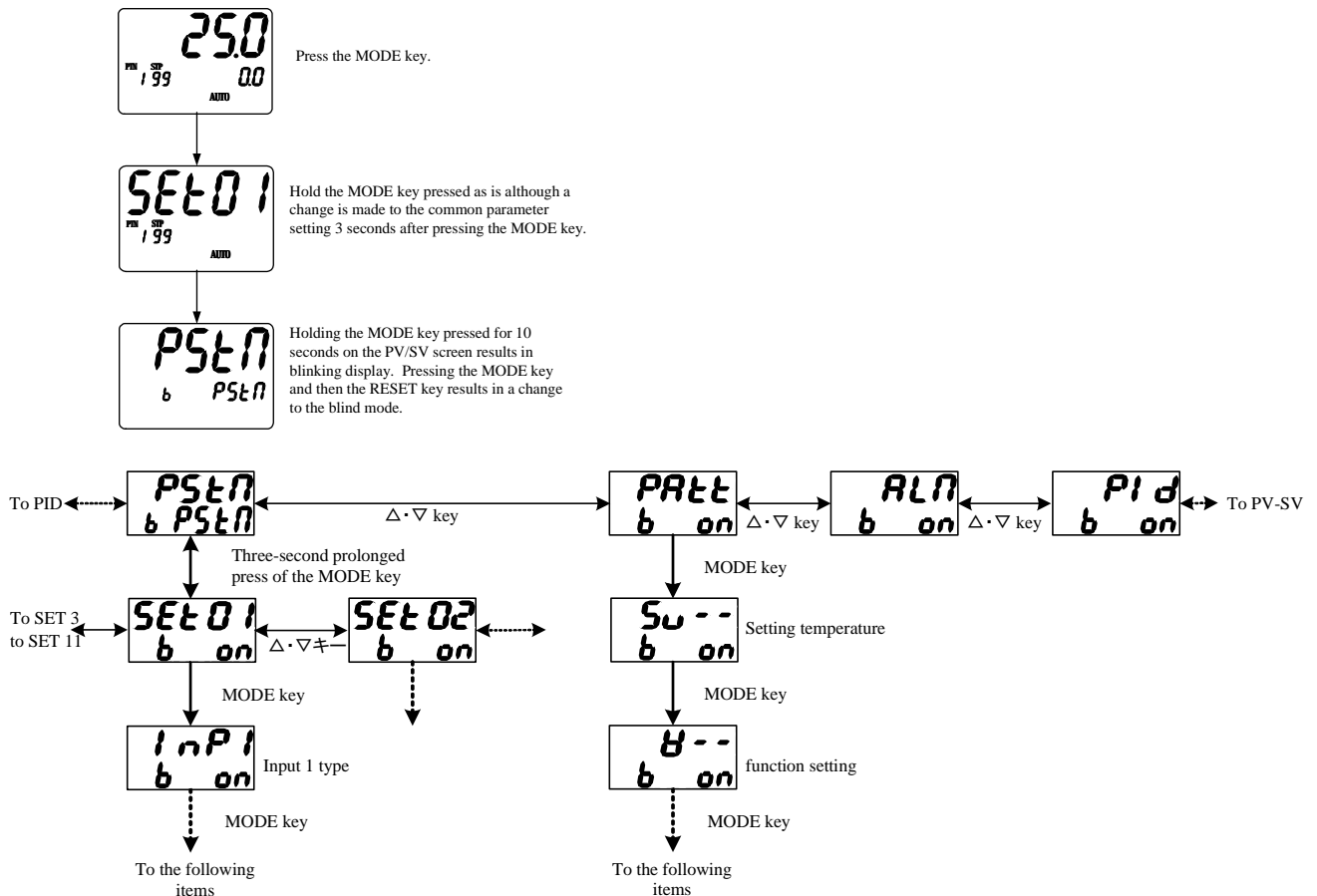

- Holding the MODE key pressed for 10 seconds on the PV/SV screen results in the blind mode.
- In the blind mode, “ON” and “OFF” are displayed in the lower row for each character (SV display section). “ON” indicates display and “OFF” indicates no display (blind). Note that a batch setting applies for the PV/SV screen, elapsed time screen and operation amount screen.
- For a character change in the blind mode, use the DSP.CHG key.
- To terminate the blind setting mode, either turn off the power or hold the MODE key pressed for 10 seconds on the PV/SV screen.
- For blind items, see “L/B” in the column of “Command” in Operation Specifications “List of communications items.”

4.19 Electric Power Outage Function

- Upon recovery of the electric power after its outage during a run, the status at the time of the outage is restored under the following conditions. Note that, if the PV at restoration is out of the range of $[PV \pm \text{electric power outage restoration temperature width}]$, the restoration is made as a stop.
 - Alarm statuses of the event function are also restored.
- 1) If the step 1 is in the status of a timer run (SV=SLL):
→ Restored at the location at the time of the outage.
 - 2) In the case of in-a-ramp of SV increase or in-a-soak:
→ Restored with the PV start.
Restored with the run end "END" if no SV present.
 - 3) In the case of in-a-ramp of a SV decrease or in-a-soak after the decrease:
→ Restored with the PV start at the step of the decrease if $PV > \text{decrease point}$.
Restored with the run end "END" if $PV \leq \text{decrease point}$.
 - 4) In the case of in-"END":
→ Restored to "END."
 - 5) Restored with a temporary stop for the items 1 through 3 if a power outage occurs during a temporary stop.
 - 6) In the case of in-a-manual-run:
→ Restored with a stop status.

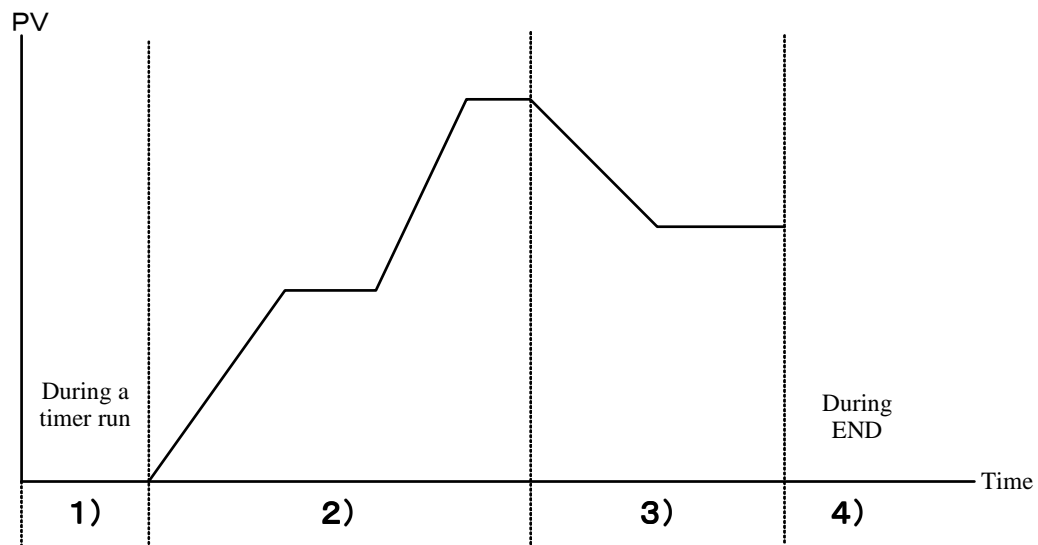

5. Flow of Mode Change Operation and Run Operation

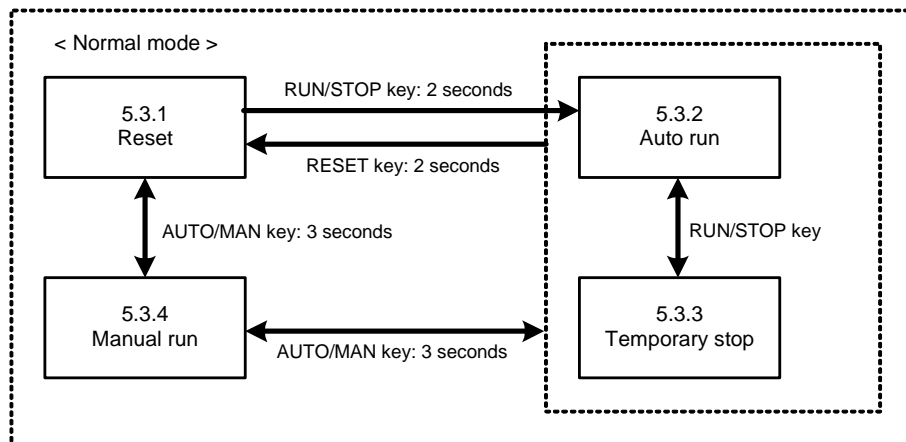
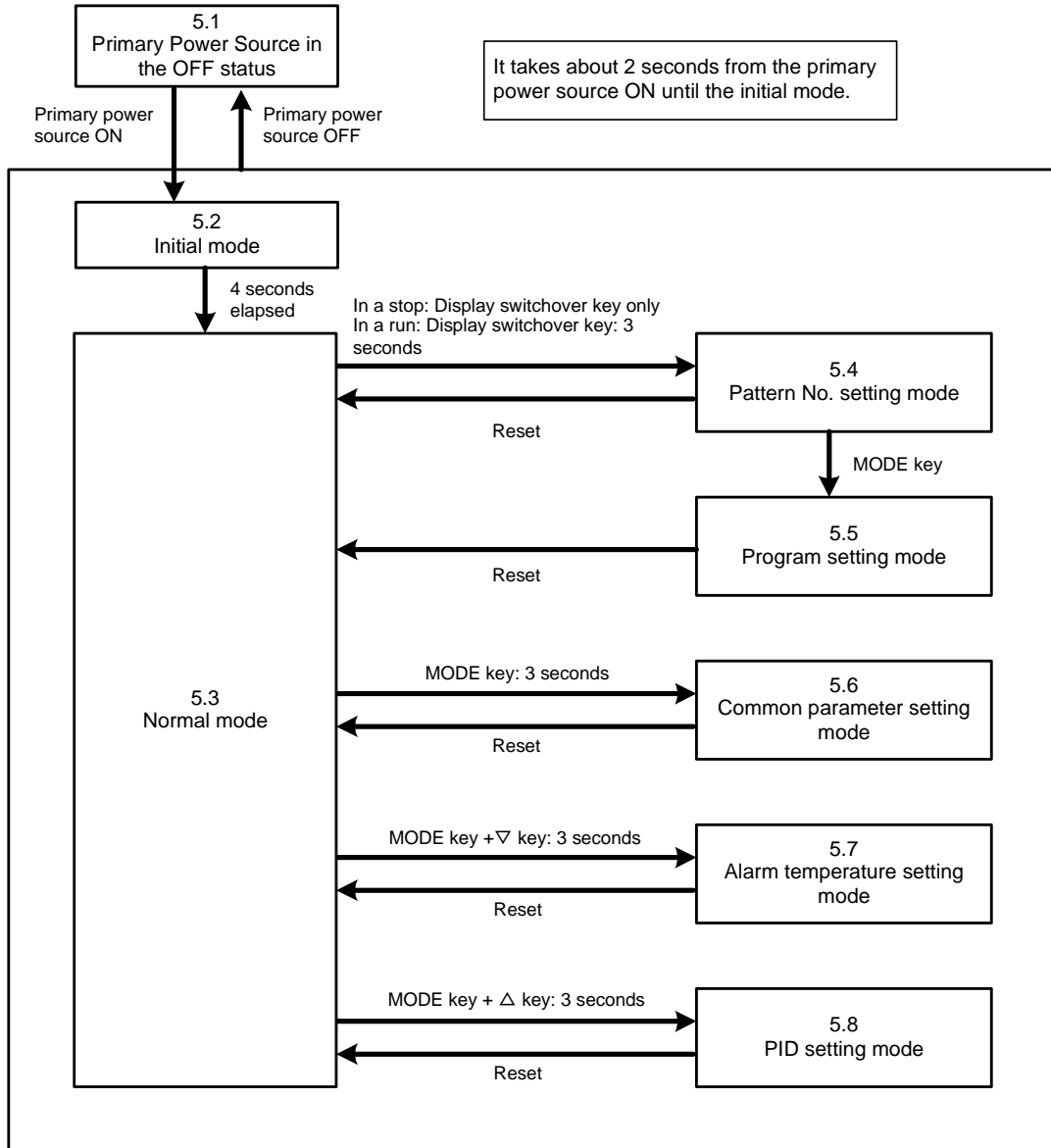

Flow of the program setting mode

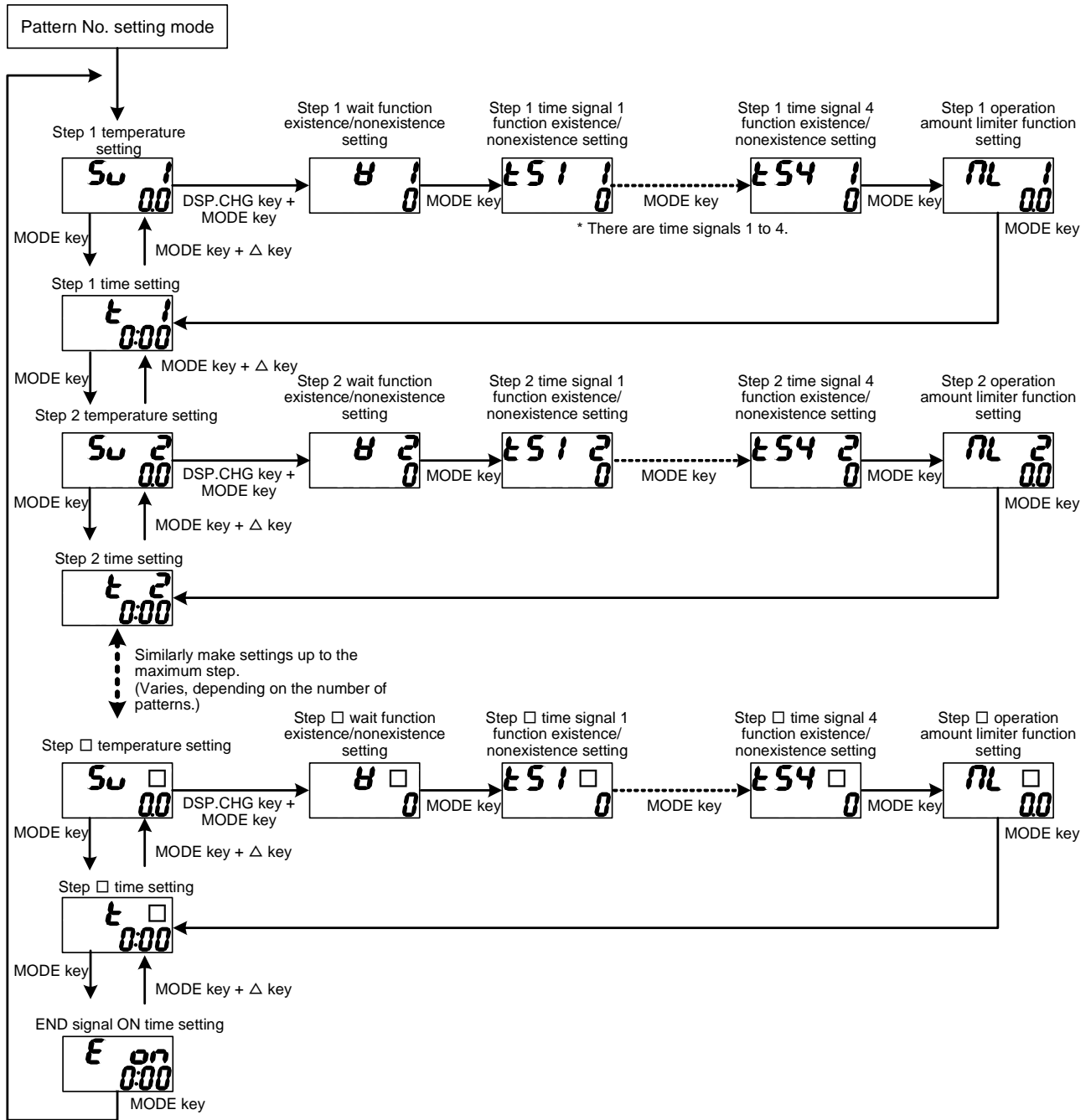

Flow of the Common parameter setting mode

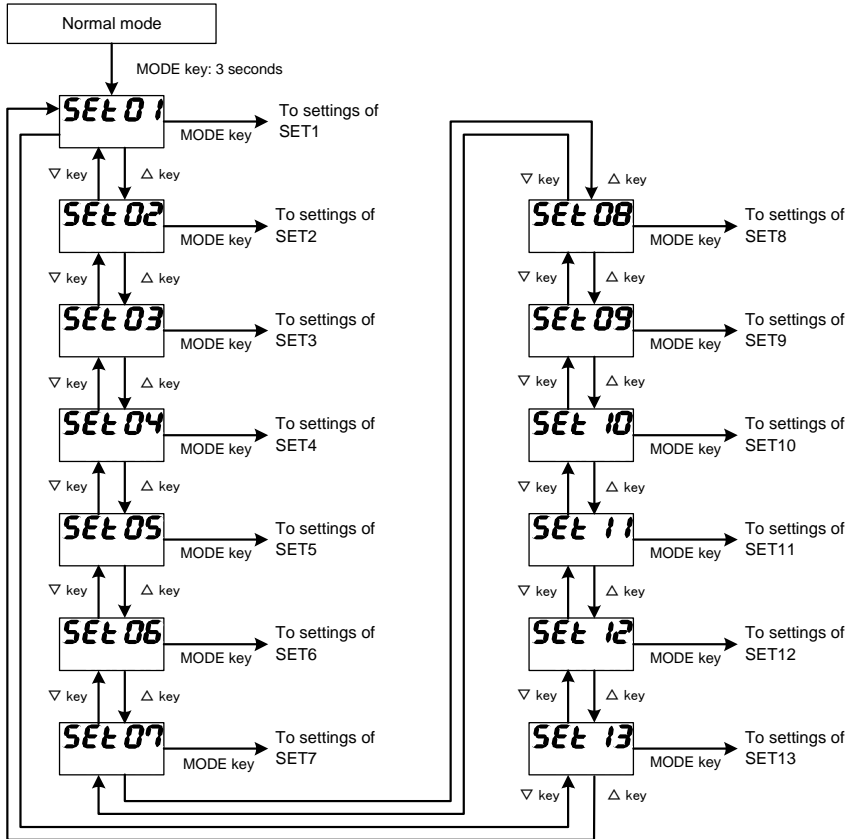

Flow of the Alarm temperature setting mode

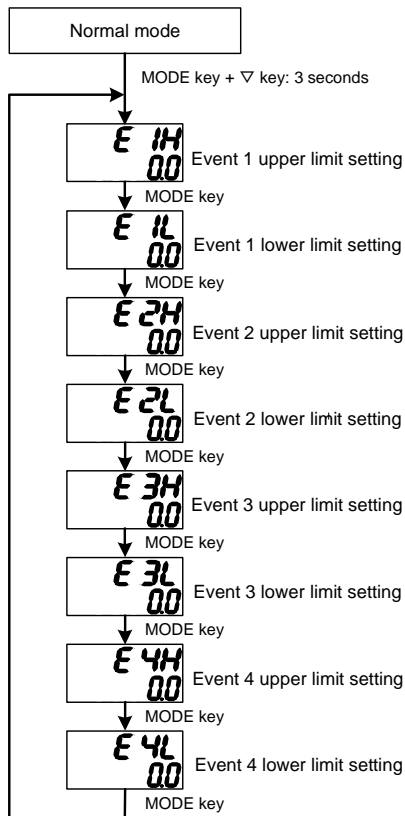

Flow of the PID setting mode

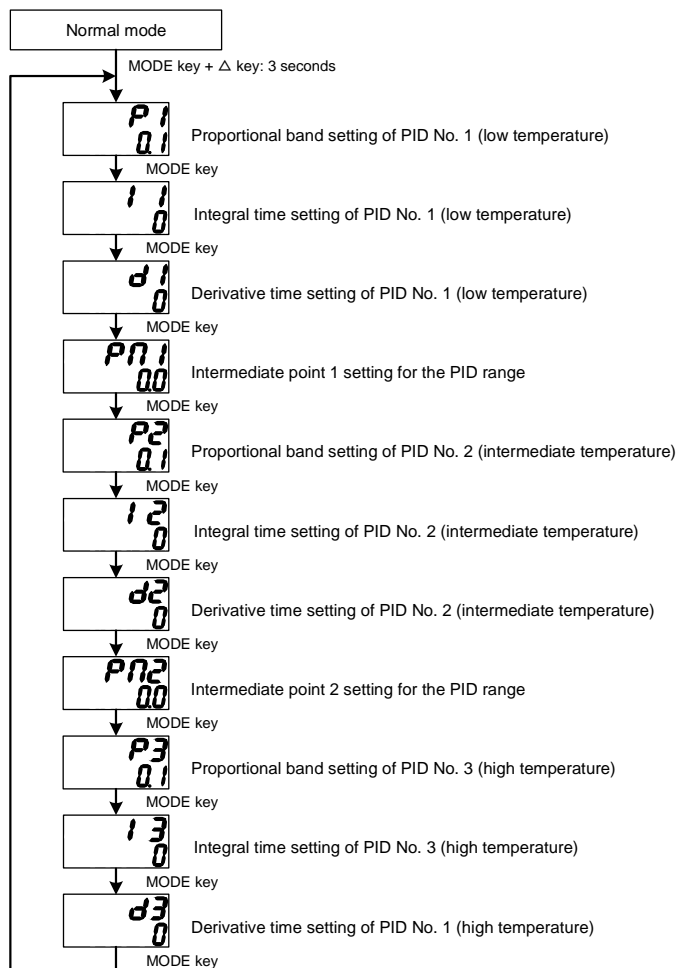

5.1 List of settings in the pattern No. setting and program setting modes

		Name	Setting content	Initial value
1	SV *	Setting temperature (*1)	- (Termination of a run); SLL to SLH	0
2	W *	Wait function setting (*1)	0 to 4 (0 stands for no function)	0
3	TS1 *	Time signal 1 function setting (*1)	0 to 5 (0 stands for no function and 5 for in-a-selection step ON)	0
4	TS2 *	Time signal 2 function setting (*1)	0 to 5 (0 stands for no function and 5 for in-a-selection step ON)	0
5	TS3 *	Time signal 3 function setting (*1)	0 to 5 (0 stands for no function and 5 for in-a-selection step ON)	0
6	TS4 *	Time signal 4 function setting (*1)	0 to 5 (0 stands for no function and 5 for in-a-selection step ON)	0
7	ML *	Operation amount limiter function setting (*1)	0 to 4 (0 stands for no function)	0
8	T *	Setting time (*1)	0:00 to 99:59 (hour: minute); ~ (endless setting)	00:00
9	RNC	running times	0 - 99 times (0 for infinite number)	1
10	E ON	End signal ON time	0:00 to 99:59 (hour: minute); ~ (ON hold)	00:00

5.2 Common parameter setting mode SET 1

	SET01	Name	Setting content	Initial value
1	PAT	Number-of-patterns setting (*2) (*3)	1 to 15 (pattern)	1
2	PVSV	PV start/SV start selection (*2)	PV PV start	PV
			SV SV start	
3	SVSV	Start temperature setting at SV start (*2)	Thermocouple/RTD input SLL to SLH (°C)	0
			Current/voltage input SLL to SLH (digit)	
4	RNES	In-a-run output/end signal output selection (*2)	0 In-a-run output	0
			1 End signal output	
5	ERUN	External drive signal selection (*2)	OFF Internal run	OFF
			ON External run	
6	TPV	Power outage restoration temperature width setting	Thermocouple/RTD input 0.0 to 2999.9 (°C) or 0 to 2999 (°C)	0
			Current/voltage input 0 to 29999 (digit)	

5.3 Common parameter setting mode SET 2

	SET02	Name	Setting content	Initial value
* Below, 1 and 2 are for the wait function setting, i.e., effective when 1 is selected.				
1	WZ1	Wait zone 1 setting	Thermocouple/RTD input 0.0 to 999.9 (°C) or 0 to 999 (°C)	0
			Current/voltage input 0 to 9999 (digit)	
2	WT1	Wait time 1 setting	0:00 to 99:59 (hour: minute)	00:00
* Below, 3 and 4 are for the wait function setting, i.e., effective when 2 is selected.				
3	WZ2	Wait zone 2 setting	same as Wait zone 1	0
4	WT2	Wait time 2 setting		00:00
* Below, 5 and 6 are for the wait function setting, i.e., effective when 3 is selected.				
5	WZ3	Wait zone 3 setting	same as Wait zone 1	0
6	WT3	Wait time 3 setting		00:00
* Below, 7 and 8 are for the wait function setting, i.e., effective when 4 is selected.				
7	WZ4	Wait zone 4 setting	same as Wait zone 1	0
8	WT4	Wait time 4 setting		00:00

5.4 Common parameter setting mode SET 3

	SET03	Name	Setting content	Initial value
* Below, 1 and 2 are for the time signal function setting, i.e., effective when 1 is selected.				
1	ONT1	Time signal ON delay timer 1	0:00 to 99:59 (hours:minutes)	00:00
2	OFT1	Time signal OFF delay timer 1	0:00 to 99:59 (hours:minutes)	00:00
* Below, 3 and 4 are for the time signal function setting, i.e., effective when 2 is selected.				
3	ONT2	Time signal ON delay timer 2	0:00 to 99:59 (hours:minutes)	00:00
4	OFT2	Time signal OFF delay timer 2	0:00 to 99:59 (hours:minutes)	00:00
* Below, 5 and 6 are for the time signal function setting, i.e., effective when 3 is selected.				
5	ONT3	Time signal ON delay timer 3	0:00 to 99:59 (hours:minutes)	00:00
6	OFT3	Time signal OFF delay timer 3	0:00 to 99:59 (hours:minutes)	00:00
* Below, 7 and 8 are for the time signal function setting, i.e., effective when 4 is selected.				
7	ONT4	Time signal ON delay timer 4	0:00 to 99:59 (hours:minutes)	00:00
8	OFT4	Time signal OFF delay timer 4	0:00 to 99:59 (hours:minutes)	00:00

5.5 Common parameter setting mode SET 4 (1)

	SET04	Name	Setting content	Initial value
1	SLH	SV limiter upper limit (*2) (*3)	Thermocouple/RTD input (SLL + 5.0) to SV setting range upper limit (°C) (SLL + 5) to SV setting range upper limit (°C)	1200
			Current/voltage input (SLL + 50) to SV setting range upper limit (digit)	12000
2	SLL	SV limiter lower limit (*2) (*3)	Thermocouple/RTD input SV setting range lower limit to (SLH - 5.0) (°C) SV setting range lower limit to (SLH - 5) (°C)	0
			Current/voltage input (SLH - 50) to SV setting range lower limit (digit)	
3	CNT	Control type setting	1 Primary...pid control Secondary---None	1
			2 Primary---onoff control Secondary---None	
			3 Primary---pid control Secondary---pid control	
			4 Primary---pid control Secondary---onoff control	
			5 Primary---onoff control Secondary---onoff control	
4	DIR	Forward/reverse operation setting	0 Reverse operation	0
			1 Forward operation	
5	MV1	Primary control operating amount	0.0 to 100.0 (%)	0.0
6	TUN	Tuning type setting	1 Primary auto-tuning	1
			2 Secondary auto-tuning	
			3 Primary/secondary auto-tuning	
7	ATG	AT coefficient setting	0.1 to 10.0 (times)	1.0
8	ATC	AT sensitivity setting	Thermocouple/RTD input 0.0 to 999.9 (°C) 0 to 999 (°C)	2
			Voltage/current input 0 to 9999 (digit)	
9	AT1	AT startup screen for PID No. 1 (low temperature)	Startup starts/stops by setting a SV and using the RUN/STOP key. Characters and PV are alternately displayed in the PV digit during AT. The SV range is SLL to PM1 .	0
10	AT2	AT startup screen for PID No. 2 (intermediate temperature)	Startup starts/stops by setting a SV and using the RUN/STOP key. Characters and PV are alternately displayed in the PV digit during AT. The SV range is PM1 to PM2 .	0
11	AT3	AT startup screen for PID No. 3 (high temperature)	Startup starts/stops by setting a SV and using the RUN/STOP key. Characters and PV are alternately displayed in the PV digit during AT. The SV range is PM2 to SLH .	10
12	ATALL	AT startup screen for PID No. 1~3	Use the RUN/STOP key for start and stop. During the auto tuning, Character//PV is alternately displayed at PV display, and No. 1 - 3/SV are alternately displayed at SV display.	
13	P1	Proportional band setting for PID No. 1 (low temperature)	0.1 to 200.0 (%)	3.0
14	I1	Integral time setting for PID No. 1 (low temperature)	0 to 3600 (seconds)	0
15	D1	Derivative time setting for PID No. 1 (low temperature)	0 to 3600 (seconds)	0
16	PM1	Intermediate point 1 setting for the PID range	Thermocouple/RTD input SLL to SLH - 5.0 (°C) SLL to SLH - 5 (°C)	0
			Current/voltage input SLL to SLH - 50 (digit)	0
17	P2	Proportional band setting for PID No. 2 (intermediate temperature)	0.1 to 200.0 (%)	3.0
18	I2	Integral time setting for PID No. 2 (intermediate temperature)	0 to 3600 (seconds)	0
19	D2	Derivative time setting for PID No. 2 (intermediate temperature)	0 to 3600 (seconds)	0
20	PM2	Intermediate point 2 setting for the PID range	PM1 to SLH (°C)	10
21	P3	Proportional band setting for PID No. 3 (high temperature)	0.1 to 200.0 (%)	3.0
22	I3	Integral time setting for PID No. 3 (high temperature)	0 to 3600 (seconds)	0
23	D3	Derivative time setting for PID No. 3 (high temperature)	0 to 3600 (seconds)	0
24	T1	Primary control proportional cycle	0.1 to 120.0 (seconds)	1.0
25	ARW	Anti-reset windup	0.0 to 110.0 (%) Function turned off at 110.0 (%) setting	110.0
26	PS1	Primary control loop abnormalityPV variation setting	Thermocouple/RTD input 0.0 to 999.9 (°C) or 0 to 999 (°C)	0
			Current/voltage input 0 to 9999 (digit)	
27	LOP1	Primary control loop abnormality time setting	0 to 3600 (seconds)	0
28	CMOD	Primary control off-point position selection setting	0 SV unit setting	0
			1 Upper	
			2 Middle	
			3 Lower	
29	C1	Primary control sensitivity control	Thermocouple/RTD input 0.0 to 999.9 (°C) 0 to 999 (°C)	1
			Current/voltage input 0 to 9999 (digit)	10
30	CP1	Primary control off-point position	Thermocouple/RTD input -999.9 to 999.9 (°C) -999 to 999 (°C)	0
			Current/voltage input -9999 to 9999 (digit)	

5.5 Common parameter setting mode SET 4 (2)

	SET04	Name	Setting content	Initial value	
31	MV2	Secondary control operating amount	0.0 to 100.0 (%)	0.0	
32	PC1	Secondary control proportional band setting for PID No. 1 (low temperature)	0.10 to 10.00 (times)	1.00	
33	PC2	Secondary control proportional band setting for PID No. 2 (intermediate temperature)	0.10 to 10.00 (times)	1.00	
34	PC3	Secondary control proportional band setting for PID No. 3 (high temperature)	0.10 to 10.00 (times)	1.00	
35	T2	Secondary control proportional cycle	0.1 to 120.0 (seconds)	1.0	
36	PS2	Secondary control loop abnormality PV variation setting	Thermocouple/RTD input 0.0 to 999.9 (°C) or 0 to 999 (°C)	0	
			Current/voltage input 0 to 9999 (digit)		
37	LOP2	Secondary control loop abnormality time setting	0 to 3600 (seconds)	0	
38	C2	Secondary control sensitivity setting	Thermocouple/RTD input 0.0 to 999.9 (°C) 0 to 999 (°C)	1	
			Current/voltage input 0 to 9999 (digit)	10	
39	CP2	Secondary control off-point position	Thermocouple/RTD input -999.9 to 999.9 (°C) -999 to 999 (°C)	0	
			Current/voltage input -9999 to 9999 (digit)		
40	PBB	Manual reset	0.0 to 100.0 (%) when CNT = 1 -100.0 to 100.0 (%) when CNT = 3 and 4	0.0	
41	DB	Dead band	Thermocouple/RTD input -999.9 to 999.9 (°C) -999 to 999 (°C)	0	
			Current/voltage input -9999 to 9999 (digit)		
42	O1F	Target connection output 1 selection	Connection content selection		
			0	MV1	0
			1	MV2	
			2	Transmission output	
43	TRN1	Transmission output function setting	Transmission content selection		
			*1	PV (measurement value) output	03
			*2	SV (setting value) output	
			*3	MV 1 (Primary Control Amt.) output	
			*4	MV 2 (Secondary Control Amt.) output	
			Forward/reverse operation selection		
			0*	Forward operation	
1*	Reverse operation				
44	TRH1	Transmission scaling upper limit setting	TRL1 ~2999.9() or TRL1 ~2999()	1200	
45	TRL1	Transmission scaling lower limit setting	-1999.9 ~ TRH1 () or -1999 ~ TRH1 ()	0	
46	O2F	Target connection output 1 selection	Connection content selection		
			0	MV1	1
			1	MV2	
			2	Transmission output	
47	TRN2	Transmission output function setting	Transmission content selection		
			*1	PV (measurement value) output	04
			*2	SV (setting value) output	
			*3	MV1 (Primary Control Amt.) output	
			*4	MV2 (Secondary Control Amt.) output	
			Forward/reverse operation selection		
			0*	Forward operation	
1*	Reverse operation				
48	TRH2	Transmission scaling upper limit setting	TRL2 ~2999.9() or TRL2 ~2999()	1200	
49	TRL2	Transmission scaling lower limit setting	-1999.9 ~ TRH2 () or -1999 ~ TRH2 ()	0	

5.6 Common parameter setting mode SET 5 to 8

	SET05 to SET08	Name	Setting content		Initial value		
1	E*F1	Event function 1 setting	Function		Add-on function		
			0	None	0	None	
			1	Deviation upper and lower limits	1	Hold	
			2	Deviation upper limit	2	Standby	
			3	Deviation lower limit	3	Delay	
			4	Deviation range	4	Hold + standby	
			5	Absolute value upper and lower limits	5	Hold + Delay	
			6	Absolute value upper limit	6	Standby + Delay	
			7	Absolute value lower limit	7	Hold + standby + Delay	
		*8	Absolute value range				
2	E*H	Event upper limit setting	Thermocouple/RTD input -1999.9 to 2999.9 (°C) -1999 to 2999 (°C) Note that for R, B and PR40-20 of thermocouple, the following is to be applied. -1999 to 9999 (°C)		0		
			Current/voltage input -19999 to 29999 (digit)				
3	E*L	Event lower limit setting	Thermocouple/RTD input -1999.9 to 2999.9 (°C) -1999 to 2999 (°C) Note that for R, B and PR40-20 of thermocouple, the following is to be applied. -1999 to 9999 (°C)		0		
			Current/voltage input -19999 to 29999 (digit)				
4	E*C	Event sensitivity setting	Thermocouple/RTD input 0.0 to 999.9 (°C) 0 to 999 (°C)		0		
			Current/voltage input 0 to 9999 (digit)				
5	E*T	Event Delay timer setting	0 to 9999 (second)		0		
6	E*F2	Event function 2 setting (loop abnormality)	Function		Add-on function		
			0	Nonexistent	0	None	
			1	Existent	1	Hold	
7	E*P	Event polarity setting	0	Normal open	1	Normal close	0

5.7 Common parameter setting mode SET 9 (1)

	SET09	Name	Setting content		Initial value		
1	MLF	Operation amount function setting	0	None	2	Operation amount current limiter(average)	0
			1	Operation amount limiter	3	Operation amount current limiter(R.M.S)	
			With the selection of [MLF =1], the following 2 to 9 are selectable for [CNT =1]; the following 2 to 17 are selectable for [CNT = 3 or 4]. * Below, 2 and 3 are for the operation amount limiter function setting, i.e., effective when 1 is selected.				
2	MLH11	Primary control operation amount limiter upper limit 1	MLL11 to 100.0(%)		100.0		
3	MLL11	Primary control operation amount limiter lower limit 1	0.0 to MLH11(%)		0.0		
* Below, 4 and 5 are for the operation amount limiter function setting, i.e., effective when 2 is selected.							
4	MLH21	Primary control operation amount limiter upper limit 2	MLL21 to 100.0(%)		100.0		
5	MLL21	Primary control operation amount limiter lower limit 2	0.0 to MLH21(%)		0.0		
* Below, 6 and 7 are for the operation amount limiter function setting, i.e., effective when 3 is selected.							
6	MLH31	Primary control operation amount limiter upper limit 3	MLL31 to 100.0(%)		100.0		
7	MLL31	Primary control operation amount limiter lower limit 3	0.0 to MLH31(%)		0.0		
* Below, 8 and 9 are for the operation amount limiter function setting, i.e., effective when 4 is selected.							
8	MLH41	Primary control operation amount limiter upper limit 4	MLL41 to 100.0(%)		100.0		
9	MLL41	Primary control operation amount limiter lower limit 4	0.0 to MLH41(%)		0.0		
* Below, 10 and 11 are for the operation amount limiter function setting, i.e., effective when 1 is selected.							
10	MLH12	Secondary control operation amount limiter upper limit 1	MLL12 to 100.0(%)		100.0		
11	MLL12	Secondary control operation amount limiter lower limit 1	0.0 to MLH12(%)		0.0		
* Below, 12 and 13 are for the operation amount limiter function setting, i.e., effective when 2 is selected.							
12	MLH22	Secondary control operation amount limiter upper limit 2	MLL22 to 100.0(%)		100.0		
13	MLL22	Secondary control operation amount limiter lower limit 2	0.0 to MLH22(%)		0.0		
* Below, 14 and 15 are for the operation amount limiter function setting, i.e., effective when 3 is selected.							
14	MLH32	Secondary control operation amount limiter upper limit 3	MLL32 to 100.0(%)		100.0		
15	MLL32	Secondary control operation amount limiter lower limit 3	0.0 ~ MLH32(%)		0.0		
* Below, 16 and 17 are for the operation amount limiter function setting, i.e., effective when 4 is selected.							
16	MLH42	Secondary control operation amount limiter upper limit 4	MLL42 to 100.0(%)		100.0		
17	MLL42	Secondary control operation amount limiter lower limit 4	0.0 to MLH42(%)		0.0		

5.7 Common parameter setting mode SET 9 (2)

	SET09	Name	Setting content	Initial value
With the selection of [MLF = 2,3], the following 18 to 41 are selectable.				
18	CM1	CT1 current value monitor	0.0 to 50.0 (A) Displays the average at MLF=2. Displays the R.M.S at MLF=3.	
19	OH01	Operation amount limiter point 1	A point is defined as a location corresponding to the number resulted from calculation of divided values of SLL to SLH into 10 equal segments multiplied by the point No. 0.0 to 100.0 (%)	100.0
20	OH02	Operation amount limiter point 2		
21	OH03	Operation amount limiter point 3		
22	OH04	Operation amount limiter point 4		
23	OH05	Operation amount limiter point 5		
24	OH06	Operation amount limiter point 6		
25	OH07	Operation amount limiter point 7		
26	OH08	Operation amount limiter point 8		
27	OH09	Operation amount limiter point 9		
28	OH10	Operation amount limiter point 10		
29	OH11	Operation amount limiter point 11		
30	AH01	Current value limiter point 1	Upper current limit at the operation amount limiter point 0.0 to 30.0 (A)	30.0
31	AH02	Current value limiter point 2		
32	AH03	Current value limiter point 3		
33	AH04	Current value limiter point 4		
34	AH05	Current value limiter point 5		
35	AH06	Current value limiter point 6		
36	AH07	Current value limiter point 7		
37	AH08	Current value limiter point 8		
38	AH09	Current value limiter point 9		
39	AH10	Current value limiter point 10		
40	AH11	Current value limiter point 11		
41	AHC	Current value limiter sensitivity	0.1 to 30.0 (A)	0.2
42 and 43 are always effective; 44 and 45 are selectable when [CNT = 3].				
42	OU1	Primary control operation amount increase rate	0.0 to 549.9 (%); 0.0% indicates the function turned off.	0.0
43	OUTM1	Primary control operation amount increase time	0 to 3600 (second); 0 indicates no function.	0
44	OU2	Secondary control operation amount increase rate	0.0 to 549.9 (%); 0.0% indicates the function turned off.	0.0
45	OUTM2	Secondary control operation amount increase time	0 to 3600 (second); 0 indicates no function.	0

5.8 Common parameter setting mode SET 10

	SET10	Name	Setting content	Initial value
1	INP1	Input type setting (*2) (*3)	0 K thermocouple 11 PR40-20	0
			1 J thermocouple 12 PLII	
			2 T thermocouple 13 Pt100	
			3 E thermocouple 14 JPt100	
			4 R thermocouple 15 0 - 10 mV DC	
			5 S thermocouple 16 0 - 1 V DC	
			6 B thermocouple 17 0 - 5 V DC	
			7 N thermocouple 18 1 - 5 V DC	
			8 U thermocouple 19 0 - 10 V DC	
			9 L thermocouple 20 4 - 20 mA DC	
			10 WRe5-26	
2	FSH1	Scaling upper limit setting (*2) (*3)	Current/voltage input only FSL1 to 29999 (digit)	10000
3	FSL1	Scaling lower limit setting (*2) (*3)	Current/voltage input only -19999 to FSH1 (digit)	-10000
4	PVG1	PV compensation gain setting	0.500 to 2.000 (times)	1.000
5	PVS1	PV compensation zero setting	Thermocouple/RTD input -999.9 to 999.9 (°C) -999 to 999 (°C)	0
			Current/voltage input -9999 to 9999 (digit)	
6	PDF1	PV filter setting	0.0 to 99.9 (seconds)	0.0
7	PDFS	Special PV filter setting	0.0 to 99.9 (seconds)	0.0
8	DP1	Decimal point position setting (*2) (*3)	Thermocouple/RTD input	0
			0 Unit of 1°C	
			0.0 Unit of 0.1°C	
			Current/voltage input	
			0 1/digit	
			0.0 0.1/digit	
			0.00 0.01/digit	
			0.000 0.001/digit	
0.0000 0.0001/digit				

5.9 Common parameter setting mode SET 11

	SET11	Name	Setting content	Initial value
1	BKUP	Backup of a setting value (*2) (*3)	Backup begins by holding the Δ and ∇ keys pressed for 2 seconds. During the backup, "SAVE" is displayed; turn-off of the display indicates ended backup.	
2	RESET	Initialization of a setting value (*2)	Initialization of the backup setting begins by holding both Δ and ∇ keys pressed for 2 seconds. During initialization, "LoAd" is displayed and turn-off of the display indicates ended initialization.	

5.10 Common parameter setting mode SET 12

	SET12	Name	Setting content	Initial value	
1	PRT	Communication protocol setting	Press the MODE key for making a setting effective.	0	
			0		TOHO protocol
			1		MODBUS protocol (RTU mode)
			2		MODBUS protocol (ASCII mode)
2	COM	Communication parameter	***1	1 bit	B8N2
			***2	2 bits	
			**N*	None	
			**0*	Odd No.	
			**E*	Even No.	
			*7**	7 bits	
			*8**	8 bits	
			N***	Nonexistent (settable for TOHO protocol)	
			B***	Existent (settable for TOHO protocol)	
3	BPS	Communication speed setting	2.4	2400 bps	9.6
			4.8	4800 bps	
			9.6	9600 bps	
			19.2	19200 bps	
			38.4	38400 bps	
4	ADR	Communication address setting	TOHO protocol	1 to 99 (stations)	1
			MODBUS protocol	1 to 247 (stations)	
5	AWT	Communication response delay time setting	0 to 250 (ms)	0	
6	MOD	Communication switchover setting	0 Write inhibit 1 Writable	1	
7	SLV	Number-of-sub-controller-connections setting (*2)	0 to 10 (unit)	0	

5.11 Common parameter setting mode SET 13

	SET13	Name	Setting content	Initial value	
1	LOC-1	Normal screen lock setting	During the lock ON, an attempt of changing a setting results in "LOC" displayed on the screen.	0	
2	LOC-2	Pattern No. setting mode lock setting			
3	LOC-3	Alarm temperature setting mode lock setting			0 Lock turned off
4	LOC-4	PID setting mode lock setting			1 Lock turned on
5	LOC01	Common parameter setting mode SET01 lock setting			
6	LOC02	Common parameter setting mode SET02 lock setting			
7	LOC03	Common parameter setting mode SET03 lock setting			
8	LOC04	Common parameter setting mode SET04 lock setting			
9	LOC05	Common parameter setting mode SET05 lock setting			
10	LOC06	Common parameter setting mode SET06 lock setting			
11	LOC07	Common parameter setting mode SET07 lock setting			
12	LOC08	Common parameter setting mode SET08 lock setting			
13	LOC09	Common parameter setting mode SET09 lock setting			
14	LOC10	Common parameter setting mode SET10 lock setting			
15	LOC11	Common parameter setting mode SET11 lock setting			
16	LOC12	Common parameter setting mode SET12 lock setting			
17	LOCS1	Setting temperature (All steps in a batch)			
18	LOCS2	Wait function setting (All steps in a batch)			
19	LOCS3	Time signal 1 function setting (All steps in a batch)			
20	LOCS4	Time signal 2 function setting (All steps in a batch)			
21	LOCS5	Time signal 3 function setting (All steps in a batch)			
22	LOCS6	Time signal 4 function setting (All steps in a batch)			
23	LOCS7	Operation amount limiter function setting (All steps in a batch)			
24	LOCS8	Setting time (All steps in a batch)			
25	LOCS9	Run times			
26	LOCSA	End signal ON time			

5.12 List of the alarm temperature setting mode setting

		Name	Setting content	Initial value
1	E1H	Event 1 upper limit setting	See Section 6.6 "Common parameter setting mode SET 5 to 8."	
2	E1L	Event 1 lower limit setting		
3	E2H	Event 2 upper limit setting		
4	E2L	Event 2 lower limit setting		
5	E3H	Event 3 upper limit setting		
6	E3L	Event 3 lower limit setting		
7	E4H	Event 4 upper limit setting		
8	E4L	Event 4 lower limit setting		

5.13 List of the PID setting mode setting

		Name	Setting content	Initial value
1	P1	Proportional band setting for PID No. 1 (low temperature)	See Section 6.5 "Common parameter setting mode SET 4."	
2	I1	Integral time setting for PID No. 1 (low temperature)		
3	D1	Derivative time setting for PID No. 1 (low temperature)		
4	PM1	Intermediate point 1 setting for the PID range		
5	P2	Proportional band setting for PID No. 2 (intermediate temperature)		
6	I2	Integral time setting for PID No. 2 (intermediate temperature)		
7	D2	Derivative time setting for PID No. 2 (intermediate temperature)		
8	PM2	Intermediate point 2 setting for the PID range		
9	P3	Proportional band setting for PID No. 3 (high temperature)		
10	I3	Integral time setting for PID No. 3 (high temperature)		
11	D3	Derivative time setting for PID No. 3 (high temperature)		

5.14 Caution

Care must be used for the names with suffixes as described below:

- *1: Setting related to steps in a run cannot be changed.
- *2: No change is possible during a run.
- *3: SAVE (all settings writing) is performed.

6. Measurement range and indicator resolution

Input type	Standards	Measurement/measurement range	Indicator resolution	
Thermocouple	K	JIS C 1602-1995	-200.0 to +1372.0	1°C / 0.1°C
	J	JIS C 1602-1995	-200.0 to +1200.0	1°C / 0.1°C
	T	JIS C 1602-1995	-200.0 to +400.0	1°C / 0.1°C
	E	JIS C 1602-1995	-200.0 to +1000.0	1°C / 0.1°C
	R	JIS C 1602-1995	-50 to +1768	1°C
	S	JIS C 1602-1995	-50 to +1768	1°C
	B	JIS C 1602-1995	0 to 1800	1°C
	N	JIS C 1602-1995	-200.0 to +1300.0	1°C / 0.1°C
	U	DIN	-200.0 to +400.0	1°C / 0.1°C
	L	DIN	-200.0 to +900.0	1°C / 0.1°C
	WRe5-26	ASTM	0 to 2300	1°C
	PR40-20	ASTM	0 to 1880	1°C
	PLII	ASTM	0.0 to 1390.0	1°C / 0.1°C
Resistance temperature detector	Pt100Ω	JIS C 1604-1997	-200.0 to +850.0	1°C / 0.1°C
	J Pt100Ω	JIS C 1604-1997	-200.0 to +510.0	1°C / 0.1°C
Voltage	0 - 1 VDC		-19999 to +29999 Display range of 20000 or less	Random change of decimal point position allowed
	0 - 5 VDC			
	1 - 5 VDC			
	0 - 10 VDC			
	0 - 10 mVDC			
Current	4 - 20 mA DC			

7. List of models

T T M - 3 3 9 - _ _ - _ _ _ _

Symbol	Item	Description	
	Size	96 x 96	
	Input	Multi-input: Thermocouple, resistance temperature detector, voltage and current	
	OUT1 (Primary control)	R	Relay contact output
		P	SSR drive voltage output (0 to 12 VDC)
		I	Current 4 to 20 mA DC output
	OUT2 (Primary/secondary control)	N	None
		R	Relay contact output
		P	SSR drive voltage output (0 to 12 VDC)
		I	Current 4 to 20 mA DC output
	Option	A	Relay contact outputs EV1 to EV3 *1
		B	Relay contact output END signal output
		C	Open collector outputs TS1 to 4, TIME, EV4 output *2
		D	CT input *3
		E	No-voltage contact input
		M	Communications RS-485
		T	English version panel sheet

*1 No EV3 if a relay contact output is selected for OUT1. No EV2 if a relay contact output is selected for OUT2.

*2 No EV4 if a relay contact output is selected for OUT1 or OUT2.

*3 Select I for OUT1 or OUT2. This CT is of a type to limit the operation amount but not to detect disconnection. It is effective for the PID control of the heat control.

8. STANDARD SPECIFICATIONS

8.1 General specifications

Memory element	EEPROM	
Input/Output isolation	Between Output area(control, event output) and Input area (process, CPU) and Power source	
Power voltage	100 - 240 VAC, 50/60 Hz (Allowable voltage range: 85 - 110 %)	
Power consumption TTM-339	10VA(AC264V)	
Momentary power cut off	Within 1 cycle(20mS), Cut 100% power off on 100V AC at max. power consumption	
Isolation resistance	Measurement terminal - case 500 VDC, 20 MΩ. Power terminal - case 500 VDC, 20 MΩ.	
Withstand voltage	Measurement terminal - case 1500 VAC for a minute. Power terminal - case 500 VAC for a minute.	
Operation environment	Temperature	0 ~ 50
	Humidity	20 - 90 %RH (no dew condensation allowed)
	Set angle	Datum surface ± 10 degrees
	Vibration	0 ~ 0.2G
Transportation/storage condition	Temperature	-20 - +70 °C (no freeze or dew condensation allowed)
	Humidity	5 - 95 %RH (no dew condensation allowed)

8.2 Standard and performance

PV input area	Input type	Thermocouple	K,J,T,E,R,S,B,N,U,L,WRe5-26,PR40-20,PL switchable. Effect of outer resistance approx.0.5 μ V/ Indicating over, when wire is disconnected
		R.T.D.	Pt100, JPt100 switchable Allowable lead wire resistance 10 or less(per wire) Indicating over, when wire is disconnected(for all of A, B and b)
	Sampling time	0.2 sec. (same as output change frequency)	
	PV correct.	-199.9 ~ 999.9 (°F) or -199 ~ 999 (°C)	
Display/Setting	Display type	PV/character	5-digit 7 segment LCD(back light colors of red, green and orange) letter height 20mm
		Set value	5-digit 7 segment LCD(back light colors of red) letter height 8mm
		Status	1-digit 6 segment LCD(back light colors of red)
		Pattern display	2-digit 7 segment LCD(back light colors of green)
		Step display	2-digit 7 segment LCD(back light colors of green)

Display/ Setting	Display type	LCD lamp red	15 pcs RUN,OUT,EV1,EV2,EV3,EV4, TS1,TS2,TS3,TS4,TIME,AUTO,MAN U,AT,END
		LCD lamp green	2 pcs PTN,STP
	Accuracy of Indication /Set ting	Thermocouple	Thermocouples of K, J, T, E, R, S, B and N Either larger $\pm (0.3 \% + 1 \text{ digit})$ or $\pm 2 \text{ }^\circ\text{C}$ of the indicated value Note: $\pm 3 \text{ }^\circ\text{C}$ for -100 to $0 \text{ }^\circ\text{C}$ and $\pm 4 \text{ }^\circ\text{C}$ for -200 to $-100 \text{ }^\circ\text{C}$ No specification for $400 \text{ }^\circ\text{C}$ or lower for B thermocouple * In standard environment conditions ($23 \pm 10 \text{ }^\circ\text{C}$) Thermocouples of U and L: Either larger $\pm (0.3 \% + 1 \text{ digit})$ or $\pm 4 \text{ }^\circ\text{C}$ of the indicated value $\pm 6 \text{ }^\circ\text{C}$ for $0 \text{ }^\circ\text{C}$ or lower WRe 5-26 Either larger $\pm (0.6 \% + 1 \text{ digit})$ or $\pm 4 \text{ }^\circ\text{C}$ of the indicated value PR 40-20 $\pm 9.4 \text{ }^\circ\text{C} \pm 1 \text{ digit}$ No accuracy specified for lower than $800 \text{ }^\circ\text{C}$ PL II Either larger $\pm (0.3 \% + 1 \text{ digit})$ or $\pm 2 \text{ }^\circ\text{C}$ of the indicated value
		R.T.D.	Either larger $\pm (0.3 \% + 1 \text{ digit})$ or $\pm 0.9 \text{ }^\circ\text{C}$ of the indicated value * In standard environment conditions ($23 \pm 10 \text{ }^\circ\text{C}$)
		Voltage	$\pm 0.3 \% \pm 1 \text{ digit}$ of FS * In standard environment conditions ($23 \pm 10 \text{ }^\circ\text{C}$) Only 0-10mV, $\pm 0.5 \% \pm 1 \text{ digit}$ of FS
		Current	$\pm 0.3 \% \pm 1 \text{ digit}$ of FS * In standard environment conditions ($23 \pm 10 \text{ }^\circ\text{C}$)
		Setting method	Set all parameters with the front keys.
	Lock functions	Normal screen lock setting, Pattern No. setting mode lock setting, Alarm temperature setting mode lock setting, PID setting mode lock setting ,26 kinds.	
Control/ output	Control type	Select from ON/OFF control, PID control .	
	Power ON	Relay contact output, SSR drive voltage output Approx. 4 sec output 0%. 4 ~ 20mA DC output Approx. 4 sec. 1mA output	
	PV abnormal	Relay contact output, SSR drive voltage output : output: 0% output (output OFF) 4 ~ 20mA DC : output: 0%	
	Standards	Relay contact output : contact specification 1a contact capacity 250VAC 3A(resistance load). SSR drive voltage output: OFF time; 0V DC ON time; 12V DC Loaded resistance over 600 . (It may vary according to a calculation with SSR inner resistance.) 4 ~ 20mA DC output: Output current 4 ~ 20mA DC Loaded resistance below 600 . Output range:DC2.4 ~ 21.6mA	
Communication	Loader communication	Communication specification : TTL level Network: point to point (1 vs 1 station) Communication distance : Use TOHO loader cable. Address : 1 - 99 stations	

Program sect ion	No. of patterns	No. of patterns 15max
	No. of steps	No. of steps 99max * The maximum No. varies depending on the selected
	Step time	0 to 99 hours 59 minutes
	Time accuracy	$\pm(0.5\% + 0.5 \text{ seconds})$ of setting time
	running times	0 - 99 times (0 for infinite number)
	wait	Wait zone : 0.0 to 999.9 $^\circ\text{C}$ Wait time : 0 to 99 hours 59 minutes
Option	Event output	Relay contact output : contact specification 1a contact capacity 250VAC 1A(resistance load).
	No-voltage contact input	OFF time voltage: 6V DC ON time current: 6mA DC Minimum input time: 200mSEC and over
	Communication	Communication specification : RS-485 network : Multidrop(1:31) Communication distance : 500 m Address : 1 - 99 stations * For MODBUS setting, 1 - 247 stations







9.MAINTENANCE AND INSPECTIONS

If any of the troubles still exists after following the above instruction, or for any other cases, contact our Sales Department.

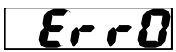
Troubles	Check points
Display does not come out.	Is instrument correctly inserted in the case? Are power terminals correctly connected? Is power sufficiently supplied?
Unable to start	Is the process value appropriate for any of the run steps after selecting PV Start?
Insufficient control	Value setting of PID constant, control sensitivity and fuzzy strength all proper?
Temperature does not increase(or decrease)	Is output terminal correctly connected? Is control type correctly set up?

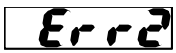
Display methods, etc. as follows are used at an abnormality.

The PV digit turns to red at occurrence of an abnormality. The lower row turns off..

Name	Display	Occurrence conditions/Release method	
Memory error		Occurrence condition: Release method:	Occurs if the recorded setting value is abnormal. Repair the board.
Temperature input circuit error		Occurrence condition: Release method:	Occurs if the temperature input circuit is abnormal. Repair the board.
Auto tuning error		Occurrence condition: Release method:	Occurs if the temperature sensor disconnected or the temperature input is out of the display range, or an auto tuning does not end after 3 hours elapsed from its start. Use either key for release.
Secondary machine communications error		Occurrence condition: Release method:	Occurs if communications with the secondary machine is abnormal. Use the RESET key for recovery.
FRAM error		Occurrence condition: Release method:	Occurs if FRAM (memory element) is abnormal. Use either key for release. Repair the substrate if re-occurs.
Temperature input upper limit error		Occurrence condition: Release method:	Occurs if the temperature sensor disconnected or the temperature input is beyond the display range upper limit. Check the temperature sensor connection; restored if the temperature input returns to within the normal range.
Temperature input lower limit error		Occurrence condition: Release method:	Occurs if the temperature input is below the display range lower limit. Check the temperature sensor connection; restored if the temperature input returns to within the normal range.



WEB.site <http://www.toho-inc.com> E-mail overseas@toho-inc.co.jp
Head office:1-13-21,Tanashioda,Tyuuohku,Sagamihara Kanagawa 252-0245 Japan
TEL +81-42-777-3311 FAX +81-42-777-3751

(C) 2010 TOHO ELECTRONICS INC. ALL rights reserved.
48 - 8364